

High accuracy thermistor

AT Thermistor

The AT series thermistor features high accuracy with tight resistance and B-value tolerances ($\pm 1\%$).

- Features:
- Uniform shape facilitates automated assembly
 - Long term reliability
 - Five different standard shapes available

Product number explanation

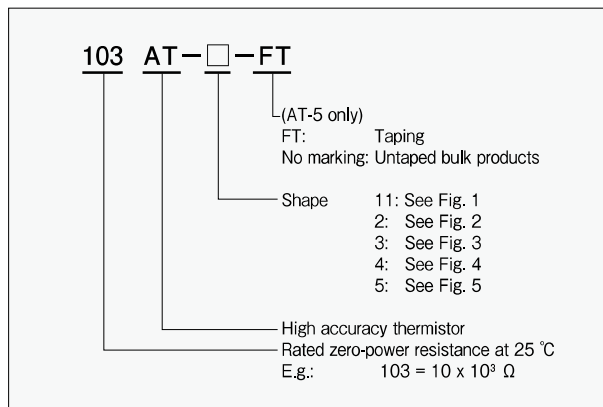

Applications

Office automation, measuring instruments, controllers, mobile devices, battery chargers, battery packs, fan motors, home electronics, HVAC equipment, solar systems, security, thermometers, automotive, vending machines, refrigerated display cases, agricultural equipment

Dimensions

Fig. 1

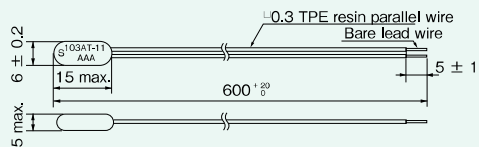

Unit: mm

Fig. 2

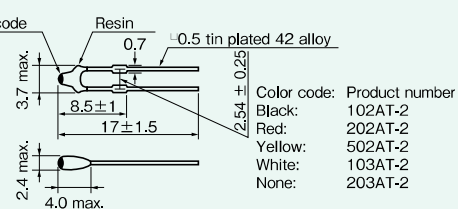

Unit: mm

Fig. 3

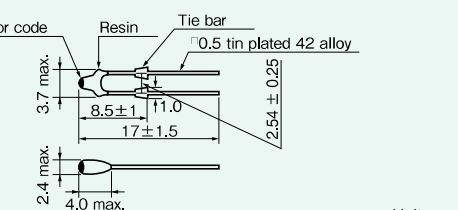

Unit: mm

Fig. 4

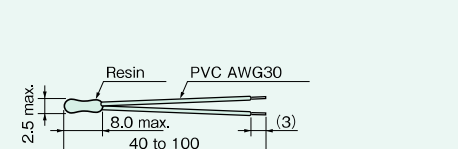

Unit: mm

Fig. 5

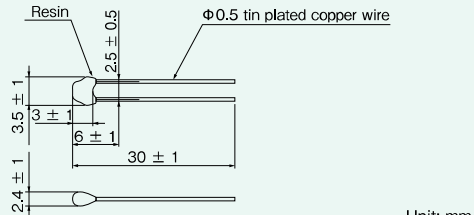

Unit: mm

Specifications

Product number	R_{25}^1	R_{25} tolerance	B value ²	Dissipation factor (mw / °C)	Thermal time constant (s) ³	Rated power at 25 °C (mW)	Operating temperature range (°C)
102AT-11	1.00 kΩ	± 1%	3100 K ± 1%	approx. 2.6	approx. 75	13	- 50 to 90
202AT-11	2.00 kΩ		3182 K ± 1%				
502AT-11	5.00 kΩ		3324 K ± 1%				
103AT-11	10.0 kΩ		3435 K ± 1%				- 50 to 105
203AT-11	20.0 kΩ		4013 K ± 1%				
102AT-2	1.00 kΩ		approx. 2.0	3100 K ± 1%	approx. 15	10	- 50 to 90
202AT-2	2.00 kΩ			3182 K ± 1%			
502AT-2	5.00 kΩ			3324 K ± 1%			
103AT-2, 3	10.0 kΩ			3435 K ± 1%			- 50 to 110
203AT-2	20.0 kΩ			4013 K ± 1%			
103AT-4	10.0 kΩ		approx. 10	3435 K ± 1%	approx. 15	12.5	- 30 to 90
103AT-5	10.0 kΩ			3435 K ± 1%			approx. 2.5

¹: Rated zero-power resistance at 25 °C ²: B value calculated from rated zero-power resistance at 25 °C and 85 °C

³: Time required to reach 63.2% of temperature difference. Measured with sensor suspended in mid-air.

Reliability data

Item	Test conditions		Criteria
Resistance to soldering heat	AT-2, 3, 4	10 s at 260 °C or 3.5 s at 350 °C	ΔR, ΔB ± 1%
	AT-5	5 s at 260 °C or 1.5 s at 350 °C	
Solderability	AT-2, 3	2 s at 245 °C. Flux material: Rosin 25%, ethyl alcohol 75%.	More than 90% soldered
	AT-4, 5	2 s at 235 °C. Flux material: Rosin 25%, ethyl alcohol 75%.	
Tensile strength (lead wire)	AT-11	10 s at 30 N (horizontal pull)	ΔR, ΔB ± 1% and visual inspection
	AT-2, 3	A load of 2 N is applied to the wire terminations in vertical direction for 10 s (see Fig. 1)	
	AT-4	60 s at 5 N (horizontal pull)	
	AT-5	A load of 2 N is applied to the wire terminations in vertical direction for 3 s (see Fig. 1)	
Termination bending	AT-11	5 N, ten times, 90°	ΔR, ΔB ± 1% and visual inspection
	AT-2, 3	One time, 90°	
	AT-4	1 N, five times, 90°	
	AT-5	2.5 N, two times, 90°	
Free fall	AT-11, 2, 3	Three times natural fall to a maple board from 1 m height.	Less than 1 mA
	AT-4	Three times natural fall to a maple board from 0.75 m height.	
	AT-5	One time natural fall to a maple board from 1 m height.	
Voltage proof	AT-11, 2, 3, 5	1000 V AC for one minute	Over 100 MΩ
	AT-4	100 V DC for one second	
Insulation resistance	AT-11, 2, 3, 5	500 V DC	ΔR, ΔB ± 1%
	AT-4	100 V DC	
Dry heat	AT-11	1000 hours at 105 °C (90 °C ⁴)	ΔR, ΔB ± 1%
	AT-2, 3, 5	1000 hours at 110 °C (90 °C ⁴)	
	AT-4	1000 hours at 90 °C	
Damp heat (under electrical load)	AT-11	1000 hours at 70 °C and 90% humidity Electrical load: 1 mA DC	ΔR, ΔB ± 1%
	AT-2, 3, 4, 5	1000 hours at 40 °C and 90% humidity Electrical load: 1 mA DC	
Temperature cycle (thermal shock)	AT-11	100 cycles as below: 1. - 55 °C for 30 minutes 2. Room temperature for 3 minutes 3. 85 °C for 30 minutes 4. Room temperature for 3 minutes	ΔR, ΔB ± 1%
	AT-2, 3	100 cycles as below: 1. - 30 °C for 30 minutes 2. Room temperature for 3 minutes 3. 90 °C for 30 minutes 4. Room temperature for 3 minutes	
	AT-4	100 cycles as below: 1. - 20 °C for 30 minutes 2. Room temperature for 1 minute 3. 70 °C for 30 minutes 4. Room temperature for 1 minute	
	AT-5	100 cycles as below: 1. - 30 °C for 30 minutes 2. Room temperature for 3 minutes 3. 90 °C for 30 minutes 4. Room temperature for 3 minutes	

⁴: Conditions for 102AT-11, 202AT-11, 102AT-2, 202AT-2

Resistance / temperature characteristics

Temperature (°C)	Product number				
	102AT	202AT	502AT	103AT	203AT
- 50	24.46	55.66	154.6	329.5	1253
- 40	14.43	32.34	88.91	188.5	642.0
- 30	8.834	19.48	52.87	111.3	342.5
- 20	5.594	12.11	32.44	67.77	190.0
- 10	3.651	7.763	20.48	42.47	109.1
0	2.449	5.114	13.29	27.28	64.88
10	1.684	3.454	8.840	17.96	39.71
20	1.184	2.387	6.013	12.09	24.96
25	1.000	2.000	5.000	10.00	20.00
30	0.8486	1.684	4.179	8.313	16.12
40	0.6189	1.211	2.961	5.827	10.65
50	0.4587	0.8854	2.137	4.160	7.181
60	0.3446	0.6587	1.567	3.020	4.943
70	0.2622	0.4975	1.168	2.228	3.464
80	0.1999	0.3807	0.8835	1.668	2.468
85	0.1751	0.3346	0.7722	1.451	2.096
90	0.1536	0.2949	0.6771	1.266	1.788
100			0.5265	0.9731	1.315
110			0.4128	0.7576	0.9807
B _{25/85}	3100 K	3182 K	3324 K	3435 K	4013 K

Unit: kΩ

Taping dimensions

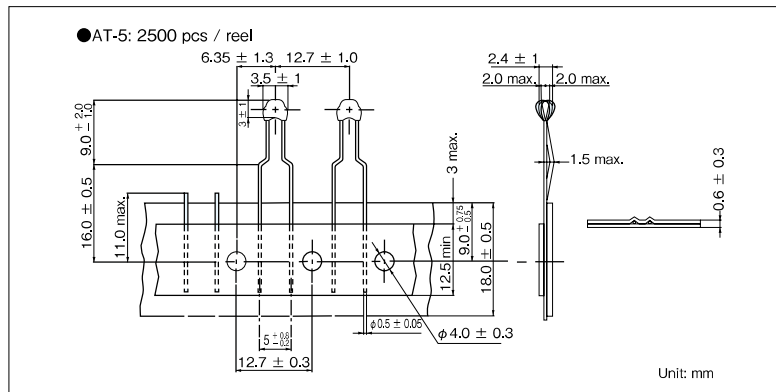

Caution

AT-2, 3, 5

- When bending the lead wires using for example a radio plier make sure to have a minimum distance from the sensor head of 3 mm.
- Do not apply a mechanical load of more than 2 N in the way depicted in Fig. 1 below. The variation of the load direction should be less than 0.3 mm (see Fig. 2).

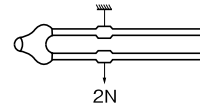

Fig. 1

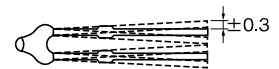

Fig. 2

- When soldering make sure to have a minimum distance of 5 mm (8.5 mm), use a soldering iron with 50 W and solder for maximum 7 (2) seconds at 340 °C (350 °C). If you plan to cut the lead wire shorter than the above minimum distance please contact us.

The values in brackets are for AT-5.

High sensitivity thermistor

ET Thermistor

The ET thermistor series features small size and high sensitivity.

- Features:
- Tight resistance and B-value tolerances; high accuracy
 - Uniform shape facilitates automated assembly
 - Long term reliability

Product number explanation

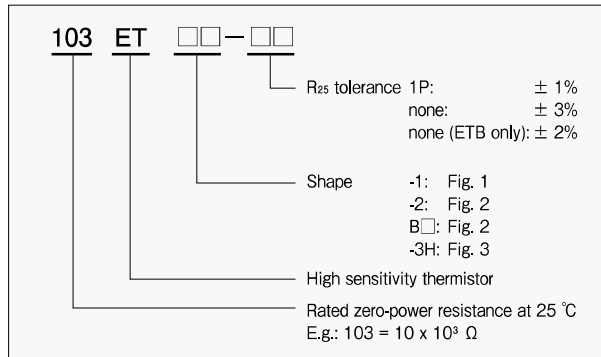

Applications

Body thermometers, thermometers, medical devices, controllers, mobile devices, battery chargers, battery packs, home electronics, toilet heaters, security, LCDs, electric vehicles

Specifications

Product number	R ₂₅ ¹	R ₂₅ tolerance	B value ²	Operating temperature range (°C)
212ET	2.10 kΩ	± 3%	3850 K ± 1%	- 40 to 90
402ET	4.00 kΩ		3100 K ± 1%	
582ET	5.80 kΩ		3614 K ± 1%	
103ET	10.0 kΩ		3250 K ± 1%	
203ET	20.0 kΩ		3450 K ± 1%	
303ET	30.0 kΩ		3760 K ± 1%	
403ET	40.0 kΩ		3525 K ± 1%	
503ET	50.0 kΩ		4055 K ± 1%	
833ET	83.0 kΩ		4013 K ± 1%	
104ET	100 kΩ		4132 K ± 1%	
224ET	226 kΩ	4021 K ± 1%	- 40 to 100	
234ET	232 kΩ	4274 K ± 1%	- 40 to 100	
103ETB	10.0 kΩ	± 1%, ± 2%	3435 K ± 1%	- 40 to 90

- Dissipation factor: 0.7 mW / °C
- Thermal time constant³: approx. 3.4 s (ET-1: approx. 3.2 s)
- Rated power at 25 °C: 3.5 mW
- ¹: Rated zero-power resistance at 25 °C
- ²: B value calculated from rated zero-power resistance at 25 °C and 85 °C
- ³: Time required to reach 63.2% of temperature difference. Measured with sensor suspended in mid-air.

Product number	R ₃₇ ⁴	R ₃₇ tolerance	B value ⁵	Operating temperature range (°C)
503ET-3H	29.937 kΩ	± 1.08%	3944 K ± 0.5%	- 40 to 100

- Dissipation factor: 0.7 mW / °C
- Thermal time constant⁶: approx. 0.8 s
- Rated power at 25 °C: 3.5 mW
- ⁴: Rated zero-power resistance at 37 °C
- ⁵: B value calculated from rated zero-power resistance at 30 °C and 45 °C
- ⁶: Time required to reach 63.2% of temperature difference. Measured with sensor immersed in oil.

Resistance / temperature characteristics

Temperature (°C)	Product number													
	212ET	402ET	582ET	103ET	203ET	303ET	403ET	503ET	833ET	104ET	224ET	234ET	103ETB	503ET-3H
- 40	64.02	57.71	127.7	170.9	402.2	810.7	833.3	1602	2664	3325	7005	9046	204.7	1588
- 30	35.13	35.34	72.10	102.2	233.6	445.1	481.1	855.0	1421	1769	3784	4680	118.5	848.1
- 20	19.65	22.38	42.37	63.07	140.2	253.7	287.5	474.4	788.5	977.5	2116	2515	71.02	470.9
- 10	11.31	14.60	25.84	40.08	86.82	149.8	177.2	272.7	453.0	559.0	1225	1401	43.67	270.4
0	6.724	9.797	16.29	26.16	55.31	91.30	112.4	161.9	269.3	329.8	730.1	808.2	27.70	160.9
10	4.130	6.737	10.57	17.51	36.16	57.31	73.00	99.13	164.8	200.5	447.8	480.2	18.07	98.63
20	2.612	4.736	7.039	11.99	24.23	37.00	48.61	62.38	103.6	125.3	282.1	293.7	12.11	62.12
25	2.100	4.000	5.800	10.00	20.00	30.00	40.00	50.00	83.00	100.0	226.0	232.0	10.00	49.77
30	1.699	3.394	4.806	8.387	16.60	24.47	33.08	40.24	66.91	80.27	182.1	184.4	8.301	40.10
40	1.134	2.476	3.353	5.988	11.61	16.56	22.96	26.58	44.18	52.62	120.3	118.6	5.811	29.937 ⁴
50	0.7753	1.835	2.369	4.353	8.279	11.45	16.26	17.93	29.80	35.23	81.07	78.00	4.147	21.72 ⁵
60	0.5420	1.378	1.685	3.217	6.005	8.070	11.70	12.33	20.51	24.00	55.75	52.39	3.011	12.20
70	0.3867	1.049	1.214	2.414	4.425	5.791	8.569	8.588	14.37	16.59	39.01	35.87	2.224	8.449
80	0.2811	0.7997	0.8863	1.836	3.310	4.222	6.367	6.064	10.24	11.64	27.78	24.99	1.668	5.940
85	0.2413	0.7005	0.7610	1.610	2.877	3.626	5.517	5.120	8.700	9.807	23.58	21.00	1.451	5.009
90	0.2079	0.6145	0.6557	1.416	2.509	3.125	4.797	4.338	7.419	8.287	20.10	17.72	1.267	4.240
100					1.926	2.346	3.662	3.142	5.459		14.75	12.75		3.070
B _{25/85}	3850 K	3100 K	3614 K	3250 K	3450 K	3760 K	3525 K	4055 K	4013 K	4132 K	4021 K	4274 K	3435 K	3944 K ⁶

⁴: Rated zero-power resistance at 45 °C

Unit: kΩ

Dimensions

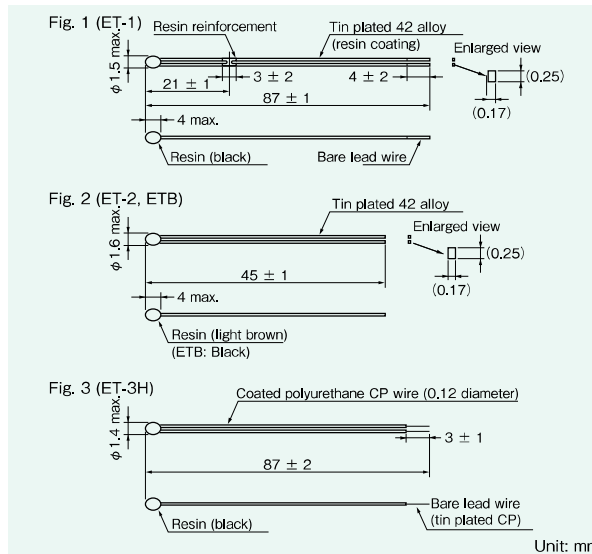

Reliability data

Item	Test conditions	Criteria
Resistance to soldering heat	10 s at 260 °C	ΔR, ΔB ± 1%
Solderability	2 s at 245 °C Flux material: Rosin 25%, ethyl alcohol 75%	More than 90% soldered
Tensile strength (lead wire)	10 s at 1 N (horizontal pull)	
Free fall	Three times natural fall to a maple board from 1 m height.	ΔR, ΔB ± 1% and visual inspection
Insulation resistance	100 V DC	Over 100 MΩ
Dry heat	1000 hours at 100 °C (90 °C ⁷)	ΔR, ΔB ± 1% (± 2% ⁷)
Damp heat (under electrical load)	1000 hours at 40 °C and 90% humidity Electrical load: 0.1 mA DC	
Temperature cycle (thermal shock)	100 cycles as below: 1. - 20 °C for 5 minutes 2. Room temperature for 3 minutes 3. 100 °C (80 °C ⁷) for 5 minutes 4. Room temperature for 3 minutes	

⁷: The value in brackets is for 212ET to 103ET, 104ET and 103ETB

Caution

- Do not apply vertical force to the lead wires exceeding 0.3 N.
- Do not apply horizontal force to the lead wires exceeding 1 N (see drawing below).
- When soldering make sure to have a minimum distance of 5 mm from the sensor head, use a soldering iron with 50 W and solder for maximum seven seconds at 340 °C.

■ High temperature, high sensitivity, glass encapsulated thermistor

NT Thermistor

Semitec's glass encapsulated NT-4 series thermistor features high heat resistance and high sensitivity. Compared with conventional thermistors, the NT-4 thermistors are smaller, faster in response, and more reliable which makes them suitable for various applications.

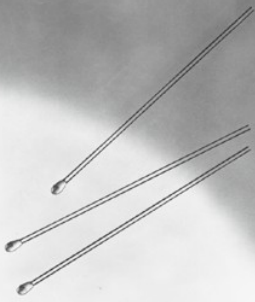

■ Product number explanation

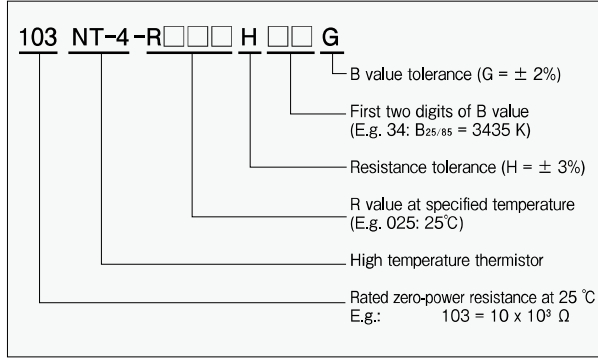

■ Dimensions

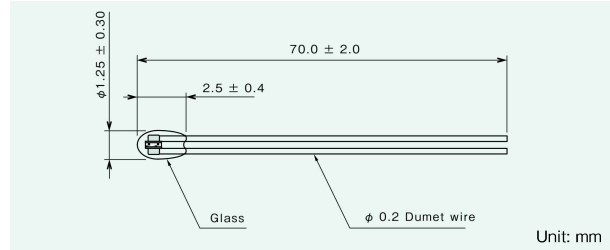

■ Applications

3D printers, HVAC equipment, water heaters, microwave ovens, home appliances, hybrid vehicles, fuel cell vehicles, automotive, medical, disaster prevention, security, office automation

■ Specifications

Product number	Rated zero-power resistance ¹		B value temperature (°C/10000)	B value ²	Operating temperature range (°C)
	Temperature	Resistance			
502NT-4-R025H39G	25 °C	5 kΩ	25/85	3964 K ± 2%	-50 to 300
852NT-4-R050H34G	50 °C	3.485 kΩ	0/100	3450 K ± 2%	
103NT-4-R025H34G	25 °C	10 kΩ	25/85	3435 K ± 2%	
103NT-4-R025H41G	25 °C	10 kΩ	25/85	4126 K ± 2%	
203NT-4-R025H42G	25 °C	20 kΩ	25/85	4282 K ± 2%	
493NT-4-R100H40G	100 °C	3.3 kΩ	0/100	3970 K ± 2%	
503NT-4-R025H42G	25 °C	50 kΩ	25/85	4288 K ± 2%	
104NT-4-R025H42G	25 °C	100 kΩ	25/85	4267 K ± 2%	
104NT-4-R025H43G	25 °C	100 kΩ	25/85	4390 K ± 2%	
204NT-4-R025H43G	25 °C	200 kΩ	25/85	4338 K ± 2%	
234NT-4-R200H42G	200 °C	1 kΩ	100/200	4537 K ± 2%	
504NT-4-R025H45G	25 °C	500 kΩ	25/85	4526 K ± 2%	
105NT-4-R025H46G	25 °C	1000 kΩ	25/85	4608 K ± 2%	

* Dissipation factor: 0.8 mw / °C • Thermal time constant⁴: approx. 6 s • Rated power at 25 °C: 4 mW
¹: Rated zero-power resistance at each temperature
²: B value calculated from rated zero-power resistance at each temperature
³: If your application requires other tolerance values please contact SEMITEC sales staff.
⁴: Time required to reach 63.2% of temperature difference. Measured with sensor suspended in mid-air.

■ Reliability data

Item	Test conditions	Criteria
Resistance to soldering heat	10 s at 260 °C (wave soldering)	ΔR ± 3%, ΔB ± 1% and visual inspection
	3.5 s at 350 °C (soldering iron)	
Solderability	2 s at 245 °C Flux material: Rosin 25%, ethyl alcohol 75%	More than 90% soldered
Tensile strength (lead wire)	10 s at 1 N (horizontal pull)	
Termination bending	0.5 N, two times, 90°	ΔR ± 3%, ΔB ± 1% and visual inspection
Free fall	Three times natural fall to a maple board from 1 m height.	
Voltage proof	500 V AC for one minute	Less than 1 mA
Insulation resistance	500 V DC	Over 100 MΩ
Dry heat	1000 hours at 300 °C	
Damp heat (under electrical load)	1000 hours at 85 °C and 85% humidity Electrical load: 0.1 mA DC	ΔR ± 3%, ΔB ± 1%
Temperature cycle (thermal shock)	100 cycles as below: 1. - 30 °C for 3 minutes in fluid 2. 150 °C for 3 minutes in fluid	

■ Resistance / temperature characteristics

Temperature (°C)	502NT-4-R025H39G	852NT-4-R050H34G	103NT-4-R025H34G	103NT-4-R025H41G	203NT-4-R025H42G	493NT-4-R100H40G	503NT-4-R025H42G	104NT-4-R025H42G	104NT-4-R025H43G	204NT-4-R025H43G	234NT-4-R200H42G	504NT-4-R025H45G	105NT-4-R025H46G
-50	339.5	346.8	394.7	830.9	1931	3376	3576	8887	10090	19040	17900	52600	110900
-30	92.34	106.1	122.0	207.7	459.2	885.4	965.0	2156	2353	4524.0	4633.0	12290	25610
-10	28.48	38.02	44.09	60.87	129.3	275.5	302.8	623.2	657.0	1284.0	1393.0	3396	6979
0	16.64	23.92	27.86	34.85	72.67	162.2	175.2	354.6	368.1	724.5	804.8	1887	3849
10	10.06	15.49	18.13	20.65	42.33	98.65	104.0	208.8	213.5	423.0	479.2	1084	2195
25	5.000	8.487	10.00	10.00	20.00	49.41	50.00	100.0	100.0	200.0	232.1	500.0	1000
40	2.649	4.899	5.806	5.166	10.10	26.23	25.42	50.90	49.90	100.6	119.0	245.2	484.7
50	1.790	3.485	4.144	3.437	6.613	17.70	16.69	33.45	32.42	65.72	78.46	157.3	308.4
60	1.238	2.524	3.011	2.341	4.440	12.20	11.19	22.48	21.54	43.89	52.84	103.1	200.7
80	0.6306	1.391	1.668	1.159	2.138	6.134	5.343	10.80	10.13	20.81	25.39	47.24	90.54
85	0.3591	1.209	1.451	0.9843	1.803	5.222	4.494	9.094	8.486	17.48	21.38	39.31	75.08
100	0.3455	0.8104	0.9754	0.6189	1.112	3.300	2.741	5.569	5.122	10.61	13.06	23.27	43.96
120	0.2014	0.4952	0.5920	0.3525	0.6175	1.882	1.498	3.058	2.763	5.759	7.130	12.23	22.78
140	0.1238	0.3108	0.3679	0.2121	0.3631	1.127	0.8635	1.770	1.574	3.301	4.098	6.787	12.48
160	0.07968	0.2000	0.2365	0.1339	0.2245	0.7057	0.5225	1.074	0.9414	1.985	2.466	3.957	7.188
180	0.05341	0.1325	0.1568	0.08811	0.1448	0.4592	0.3296	0.6793	0.5873	1.244	1.544	2.406	4.322
200	0.03708	0.09036	0.1068	0.06015	0.09698	0.3092	0.2158	0.4452	0.3804	0.8098	1.000	1.519	2.703
220	0.02656	0.06329	0.07467	0.04239	0.06713	0.2145	0.1459	0.3016	0.2549	0.5442	0.6674	0.9937	1.750
240	0.01956	0.04543	0.05345	0.03072	0.04784	0.1529	0.1016	0.2104	0.1760	0.3765	0.4574	0.6712	1.168
260	0.01477	0.03337	0.03907	0.02285	0.03499	0.1117	0.07261	0.1507	0.1250	0.2676	0.3210	0.4663	0.8019
280	0.01141	0.02506	0.02912	0.01743	0.02619	0.08336	0.05319	0.1105	0.09101	0.1950	0.2302	0.3317	0.5651
300	0.00900	0.01919	0.02209	0.01361	0.02003	0.06345	0.03981	0.08278	0.06772	0.1452	0.1683	0.2410	0.4074

■ Caution

- When soldering make sure to have a minimum distance from the glass encapsulated sensor head of 5 mm.
- When working the lead wire make sure to fix the wire at a minimum distance from the glass encapsulated sensor head of 5 mm.

Unit: kΩ

High temperature axial type thermistor

CT Thermistor

The axial glass encapsulated CT series thermistor features excellent reliability and high heat resistance.

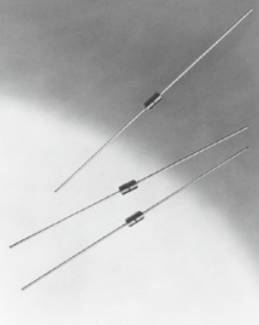

Product number explanation

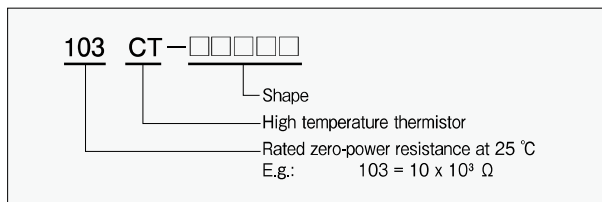

Dimensions

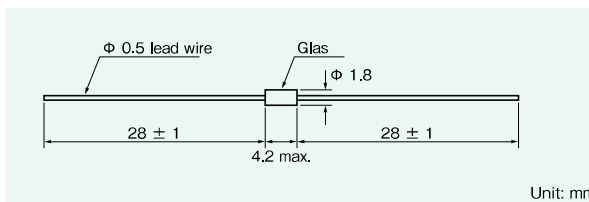

Applications

Home electronics, HVAC equipment, water heaters, kitchen appliances, solar systems, vending machines, refrigerated display cases, batteries, refrigerators

Specifications

Product number	Rated zero-power resistance ¹			B value ²	Operating temperature range (°C)	Lead wire			
	Temperature	Resistance	Resistance tolerance						
252CT-4	25 °C	2.5 kΩ	± 5%	3670 K ± 2%	- 50 to 250	Nickel plating			
512CT-4		5.1 kΩ		3200 K ± 2%	- 50 to 200				
562CT-4		5.6 kΩ		3270 K ± 2%	- 50 to 250				
912CT-4		9.1 kΩ		3270 K ± 2%	- 50 to 250				
103CT-4		10 kΩ		3270 K ± 2%	- 50 to 250				
113CT-4		11 kΩ		3270 K ± 2%	- 50 to 250				
203CT-4		20 kΩ		3410 K ± 2%	- 50 to 250				
473CT-4		47 kΩ		3610 K ± 2%	- 50 to 250				
513CT-4		51 kΩ		3610 K ± 2%	- 50 to 250				
563CT-4		56 kΩ		3610 K ± 2%	- 50 to 250				
104CT-4		100 kΩ		3450 K ± 2%	- 50 to 250				
204CT-4		200 kΩ		3500 K ± 2%	- 50 to 250				
103CT-01006		25 °C		10 kΩ	± 5%		3900 K ± 2%	- 30 to 150	Tin plating
103CT-21048		25 °C		10 kΩ	± 3%		4100 K ± 2%	- 40 to 150	
503CT-91027	50 °C	19.727 kΩ	± 2.5%	3992 K ± 2%	- 40 to 150				
104CT-90113	25 °C	100 kΩ	± 5%	4070 K ± 2%	- 40 to 150				

¹ Dissipation factor: 2.1 mW / °C ² Thermal time constant³: approx. 10 to 20 s

¹ Rated power at 25 °C: 10.5 mW

¹: Rated zero-power resistance at each temperature ²: B value calculated from rated zero-power resistance at each temperature ³: Time required to reach 63.2% of temperature difference. Measured with sensor suspended in mid-air.

Reliability data

Item	Test conditions	Criteria
Resistance to soldering heat	10 s at 260 °C (wave soldering)	ΔR, ΔB ± 2% and visual inspection
	3.5 s at 340 °C (soldering iron)	
Solderability	2 s at 245 °C Flux material: Rosin 25%, ethyl alcohol 75%	More than 50% soldered (More than 95% soldered) ^{5, 6, 7}
Tensile strength (lead wire)	10 s at 5 N (horizontal pull)	ΔR, ΔB ± 2% and visual inspection
Termination bending	2.5 N, two times, 90°	
Free fall	Three times natural fall to a maple board from 1 m height.	
Voltage proof	500 V AC for one minute	Less than 1 mA
Insulation resistance	500 V DC	Over 100 MΩ (Over 50 MΩ) ⁵
Dry heat	1000 hours at 250 °C (200 °C) ⁴ (150 °C) ^{5, 7} (125 °C) ⁶	ΔR, ΔB ± 3%
Damp heat	1000 hours at 40 °C and 90% humidity	
Temperature cycle (thermal shock)	5 cycles as below: 1. - 30 °C for 30 minutes 2. Room temperature for 3 minutes 3. 200 °C for 30 minutes 4. Room temperature for 3 minutes (min. temp. - 40 °C, max. temp. 150 °C) ^{5, 7} (min. temp. - 25 °C to 125 °C) ⁶	

⁴: 252CT, 512CT, 562CT

⁵: 103CT-21048, 103CT-01006

⁶: 503CT-91027

⁷: 104CT-90113

Resistance / temperature characteristics

Temperature (°C)	Product number															
	252CT	512CT	562CT	912CT	103CT	113CT	203CT	473CT	513CT	563CT	104CT	204CT	103CT-21048	103CT-01006	503CT-91027	104CT-90113
- 50	120.2	137.9	151.4	278.3	305.8	336.4	604.8	1506	1634	1794	3200	6803				
- 40	65.60	81.02	88.96	159.9	175.7	193.3	350.2	867.5	941.3	1034	1863	3913	458.9		1947	
- 30	36.48	48.93	53.73	94.63	104.0	114.4	207.9	512.6	556.2	610.8	1105	2306	223.1	183.3	1010	1862
- 20	20.91	30.56	33.55	58.02	63.76	70.13	127.8	313.4	340.1	373.4	675.1	1397	114.8	98.80	547.9	1011
- 10	12.32	19.65	21.58	36.67	40.29	44.32	81.00	197.2	214.0	235.0	424.3	870.3	62.13	55.69	309.7	571.0
0	7.516	12.96	14.23	23.82	26.18	28.79	52.63	127.1	138.0	151.5	272.2	553.6	35.15	32.67	181.6	334.0
10	4.738	8.779	9.639	15.92	17.49	19.24	35.15	84.16	91.32	100.3	179.4	362.5	20.70	19.86	110.2	201.7
20	3.074	6.080	6.676	10.91	11.99	13.18	24.02	56.86	61.70	67.75	120.9	242.5	12.64	12.48	68.90	125.5
25	2.500	5.100	5.600	9.100	10.00	11.00	20.00	47.00	51.00	56.00	100.0	200.0	10.00	10.00	55.06	100.0
30	2.045	4.296	4.717	7.627	8.381	9.219	16.74	39.01	42.33	46.48	83.11	165.7	7.972	8.071	44.30	80.21
40	1.393	3.095	3.398	5.442	5.980	6.578	11.88	27.07	29.37	32.25	58.24	115.4	5.177	5.362	29.22	52.55
50	0.9698	2.267	2.489	3.952	4.342	4.777	8.570	19.05	20.68	22.70	41.52	81.91	3.453	3.649	19.73	35.23
60	0.6895	1.687	1.852	2.918	3.206	3.527	6.239	13.58	14.74	16.18	30.14	59.14	2.359	2.540	13.61	24.12
70	0.4993	1.270	1.394	2.184	2.400	2.640	4.581	9.807	10.64	11.69	22.19	43.36	1.648	1.804	9.574	16.84
80	0.3680	0.9650	1.060	1.656	1.820	2.002	3.401	7.187	7.798	8.559	16.57	32.28	1.175	1.305	6.860	11.97
85	0.3178	0.8443	0.9271	1.448	1.592	1.751	2.943	6.180	6.706	7.363	14.39	27.97	0.9988	1.118	5.844	10.16
90	0.2757	0.7402	0.8128	1.269	1.394	1.534	2.553	5.328	5.781	6.348	12.53	24.33	0.8531	0.9609	4.999	8.654
100	0.2098	0.5736	0.6298	0.9787	1.076	1.183	1.937	3.997	4.337	4.762	9.586	18.57	0.6302	0.7187	3.700	6.354
120	0.1267	0.3559	0.3908	0.5952	0.6540	0.7194	1.156	2.337	2.535	2.784	5.828	11.24	0.3601	0.4196	2.115	3.574
140	0.08028	0.2298	0.2524	0.3750	0.4121	0.4533	0.7191	1.425	1.546	1.698	3.694	7.108	0.2172	0.2577	1.127	2.115
150	0.06494	0.1870	0.2053	0.3016	0.3314	0.3646	0.5752	1.129	1.226	1.346	2.982	5.732	0.1717	0.2054	1.002	1.654
160	0.05302	0.1534	0.1684	0.2445	0.2686	0.2955	0.4638	0.9031	0.9799	1.076	2.428	4.666				
180	0.03630	0.1055	0.1158	0.1643	0.1805	0.1986	0.3091	0.5919	0.6423	0.7052	1.647	3.168				
200	0.02562	0.07445	0.08175	0.1136	0.1249	0.1374	0.2122	0.4000	0.4341	0.4766	1.150	2.216				
220				0.08063	0.08860	0.09746	0.1497	0.2780	0.3016	0.3312	0.8235	1.591				
240				0.05857	0.06436	0.07080	0.1082	0.1979	0.2148	0.2358	0.6038	1.169				
250				0.05031	0.05529	0.06082	0.09271	0.1683	0.1827	0.2006	0.5208	1.010				

Caution

- When soldering make sure to have a minimum distance from the glass encapsulated sensor head of 5 mm.
- When working the lead wire make sure to fix the wire at a minimum distance from the glass encapsulated sensor head of 5 mm.

Unit: kΩ

■ Inrush current limiter

Power Thermistor

Power thermistors utilize the self heating characteristic of NTC thermistors which causes a significant decrease in resistance in a short time. Power thermistors can be used instead of inrush current limiting resistors. Power thermistors have the advantage that their resistance decreases through self heating which reduces power loss and results in energy savings.
UL1434 File No. E92669 (1D2-22 excluded) certified.

■ Product number explanation

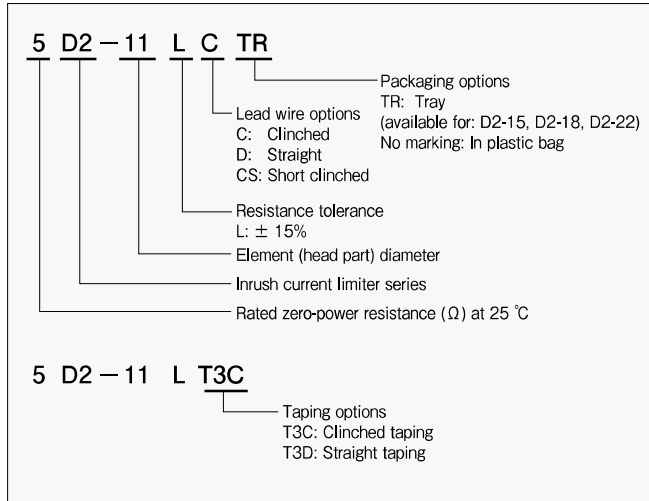

■ Applications

Switching power supplies, adapters, LCD TVs, plasma TVs, air conditioners, DVD players, audio equipment, LCD projectors, copiers, PCs, printers, office automation equipment, gaming machine power supplies

■ Dimensions

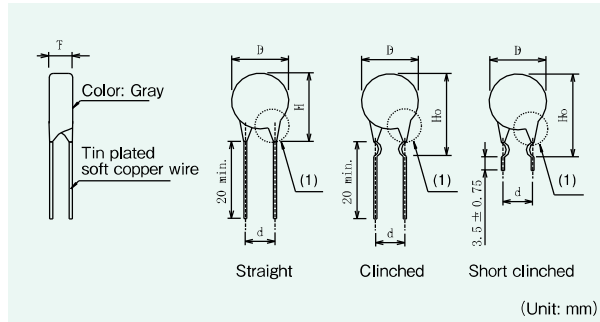

	D	T	H	H0	d	Lead wire diameter
D2-05	8.5 max.	7.0 max.	11.5 max.	15.5 max.	5.0 \pm 1	Φ 0.8
D2-07	11.0 max.	9.0 max.	13.0 max.	16.0 max.		
D2-08	10.0 max.	7.0 max.	13.0 max.	17.0 max.		
D2-10	13.0 max.	9.0 max.	17.0 max.	19.5 max.		
D2-11	11.5 max.	8.0 max.	15.0 max.	18.5 max.		
D2-13	14.5 max.	8.0 max.	18.0 max.	21.5 max.	7.5 \pm 1	Φ 1.0 (Φ 0.8)
D2-14	17.0 max.	9.0 max.	21.0 max.	22.5 max.		
D2-15	16.5 max.	8.0 max.	20.0 max.	23.0 max.		
D2-18	19.5 max.	8.0 max.	23.0 max.	26.0 max.		
D2-22	23.0 max	8.5 max, (8.0 max. ¹)	26.5 max.	29.5 max.		

¹: 1D2-22

Unit: mm

■ Taping dimensions

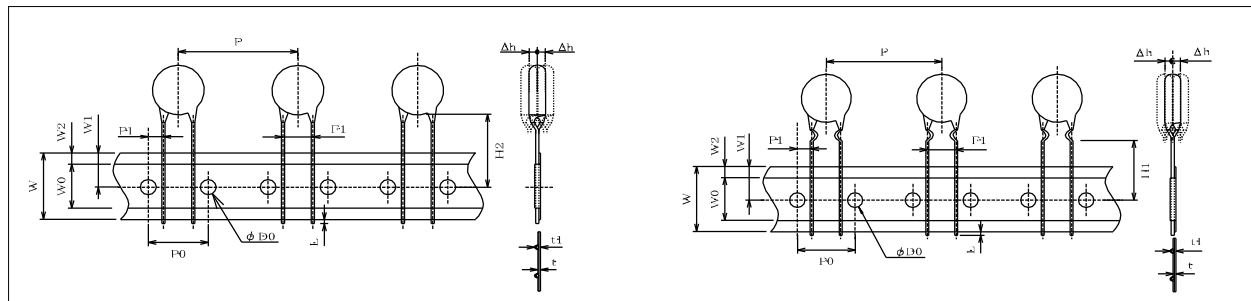

	P	P0	P1	W	W0	W1	W2	H1	H2	L	F1	Φ D0	t	t1	Δ h
D2-05	15.0 \pm 1.0	15.0 \pm 0.3	5.0 \pm 0.7	17.5 to 19.0 min. 5.0	9.0 \pm 0.5	max.3.0	16.0 \pm 0.5	19.0 to 21.5	max. 1.0		5.0 \pm 0.5	4.0 \pm 0.2	0.6 \pm 0.3	max. 1.5	0 \pm 2.0
D2-07															
D2-08															
D2-10															
D2-11	30.0 \pm 1.0		3.75 \pm 0.7								7.5 \pm 0.5				
D2-13															
D2-14															

• MOQ: 1000 pcs.

Unit: mm

Specifications

Product number	Zero-power resistance at 25 °C (± 15%) (Ω)	B value ¹ B _{25/85} (± 5%) (K)	Max. current at 25 °C (A)	Residual resistance (Ω)	Thermal time constant ² (s)	Dissipation factor (mW / °C)	Operating temp. range (°C)	Max. capacitance				Energy surge capacity (J)
								AC	AC	AC	AC	
								100 V (μF)	120 V (μF)	220 V (μF)	240 V (μF)	
5D2-05	5.0	2650	2.0	0.48	20	15	- 50 to 150	860	600	170	150	4.3
10D2-05	10.0	2700	1.0	0.91	20	7	- 50 to 150	860	600	170	150	4.3
20D2-05	20.0	2800	0.3	1.66	20	1	- 50 to 150	860	600	170	150	4.3
5D2-07	5.0	2800	3.0	0.36	35	30	- 40 to 160	400	260	80	60	1.9
8D2-07	8.0	2800	2.0	0.58	41	30	- 40 to 160	560	360	110	90	2.6
10D2-07	10.0	2800	2.0	0.72	45	30	- 40 to 160	680	470	140	110	3.3
12D2-07	12.0	2900	1.7	0.78	41	30	- 40 to 160	380	260	80	60	1.9
16D2-07	16.0	2900	2.0	1.04	45	30	- 40 to 160	800	530	160	130	3.8
22D2-07	22.0	2900	1.0	1.43	50	30	- 40 to 160	960	630	190	150	4.5
5D2-08	5.0	2700	3.0	0.35	35	22	- 50 to 170	1260	880	260	220	6.3
10D2-08	10.0	2800	2.0	0.63	35	17	- 50 to 170	1260	880	260	220	6.3
15D2-08	15.0	2800	2.0	0.94	35	26	- 50 to 170	2880	2000	590	500	14.0
20D2-08	20.0	2900	1.0	1.13	35	8	- 50 to 170	2880	2000	590	500	14.0
2D2-10	2.0	2800	5.0	0.15	50	32	- 40 to 160	640	1100	330	270	7.9
3D2-10	3.0	2800	4.0	0.22	53	32	- 40 to 160	720	1170	350	290	8.4
5D2-10	5.0	2900	4.0	0.33	53	32	- 40 to 160	440	970	290	240	7.0
8D2-10	8.0	2900	3.0	0.52	70	32	- 40 to 160	560	1070	320	260	7.7
10D2-10	10.0	2900	3.0	0.65	75	32	- 40 to 160	1640	1100	330	270	7.9
12D2-10	12.0	3000	1.8	0.71	53	32	- 40 to 160	830	580	170	140	4.1
16D2-10	16.0	3000	1.6	0.94	70	32	- 40 to 160	830	580	170	140	4.1
2D2-11	2.0	2650	5.0	0.15	40	26	- 50 to 170	2700	1880	550	470	13.0
3D2-11	3.0	2650	4.0	0.22	40	24	- 50 to 170	4830	3360	990	840	24.0
4D2-11	4.0	2700	4.0	0.28	40	31	- 50 to 170	2880	2000	590	500	14.0
5D2-11	5.0	2700	4.0	0.35	40	39	- 50 to 170	2700	1880	550	470	13.0
8D2-11	8.0	2800	3.0	0.50	40	31	- 50 to 170	2700	1880	550	470	13.0
10D2-11	10.0	2800	3.1	0.63	40	42	- 50 to 170	2880	2000	590	500	14.0
12D2-11	12.0	2800	2.0	0.75	40	21	- 50 to 170	4030	2800	830	700	20.0
15D2-11	15.0	2950	2.5	0.80	40	34	- 50 to 170	2880	2000	590	500	14.0
16D2-11	16.0	2950	2.5	0.86	40	37	- 50 to 170	2880	2000	590	500	14.0
20D2-11	20.0	3000	2.0	1.02	40	28	- 50 to 170	2880	2000	590	500	14.0
1D2-13	1.0	2650	6.0	0.06	55	12	- 50 to 200	860	600	170	150	4.3
2D2-13	2.0	2700	6.0	0.10	55	21	- 50 to 200	860	600	170	150	4.3
4D2-13	4.0	2800	5.0	0.18	55	24	- 50 to 200	860	600	170	150	4.3
4.7D2-13	4.7	2900	5.0	0.18	55	26	- 50 to 200	2700	1880	550	470	13.0
5D2-13	5.0	2900	5.0	0.19	55	27	- 50 to 200	2700	1880	550	470	13.0
8D2-13	8.0	3000	4.0	0.27	25	25	- 50 to 200	2880	2000	590	500	14.0
10D2-13	10.0	3050	4.0	0.32	55	29	- 50 to 200	2880	2000	590	500	14.0
12D2-13	12.0	3000	4.0	0.41	55	37	- 50 to 200	4830	3360	990	840	24.0
15D2-13	15.0	3050	3.0	0.48	55	25	- 50 to 200	4830	3360	990	840	24.0
16D2-13	16.0	3050	3.0	0.51	55	26	- 50 to 200	4830	3360	990	840	24.0
2D2-14	2.0	2800	5.0	0.15	90	36	- 40 to 160	4200	2890	860	720	20.8
3D2-14	3.0	2900	5.0	0.20	80	36	- 40 to 160	3080	2110	630	520	15.2
4D2-14	4.0	2900	5.0	0.26	95	36	- 40 to 160	3400	2350	700	580	16.9
5D2-14	5.0	2900	4.0	0.33	110	36	- 40 to 160	3600	2480	740	620	17.9
8D2-14	8.0	3000	2.5	0.47	80	36	- 40 to 160	1390	970	280	240	6.9
10D2-14	10.0	3000	2.2	0.59	95	36	- 40 to 160	1790	1240	370	310	8.9
12D2-14	12.0	3000	2.0	0.71	105	36	- 40 to 160	2190	1520	450	380	10.9
16D2-14	16.0	3000	1.8	0.94	115	36	- 40 to 160	2790	1940	570	480	13.9
1D2-15	1.0	2650	8.0	0.06	70	22	- 50 to 200	6910	4800	1420	1200	34.0
1.5D2-15	1.5	2650	8.0	0.08	70	29	- 50 to 200	6910	4800	1420	1200	34.0
2D2-15	2.0	2700	8.0	0.10	70	37	- 50 to 200	6910	4800	1420	1200	34.0
3D2-15	3.0	2800	7.0	0.13	70	36	- 50 to 200	4030	2800	830	700	20.0
4D2-15	4.0	2800	7.0	0.18	70	48	- 50 to 200	4030	2800	830	700	20.0
4.7D2-15	4.7	2900	6.0	0.18	70	37	- 50 to 200	4030	2800	830	700	20.0
5D2-15	5.0	2900	6.0	0.19	70	39	- 50 to 200	4030	2800	830	700	20.0
8D2-15	8.0	3000	5.0	0.27	70	39	- 50 to 200	4030	2800	830	700	20.0
10D2-15	10.0	3000	5.0	0.34	70	49	- 50 to 200	5760	4000	1190	1000	28.0
12D2-15	12.0	3050	5.0	0.39	70	54	- 50 to 200	5760	4000	1190	1000	28.0
15D2-15	15.0	3100	4.0	0.45	70	41	- 50 to 200	5760	4000	1190	1000	28.0
16D2-15	16.0	3100	4.0	0.48	70	44	- 50 to 200	5760	4000	1190	1000	28.0
4D2-18	4.0	2900	8.0	0.16	90	59	- 50 to 200	6910	4800	1420	1200	34.0
5D2-18	5.0	2950	8.0	0.18	90	66	- 50 to 200	6910	4800	1420	1200	34.0
8D2-18	8.0	3050	6.0	0.26	90	53	- 50 to 200	6910	4800	1420	1200	34.0
10D2-18	10.0	3100	6.0	0.30	90	62	- 50 to 200	6910	4800	1420	1200	34.0
4.7D2-18	4.7	3450	2.0	0.94	90	21	- 50 to 200	6910	4800	1420	1200	34.0
1D2-22	1.0	2900	12.0	0.04	125	32	- 50 to 200	8200	-	1700	-	41.0
3D2-22	3.0	2800	8.0	0.13	130	48	- 50 to 200	12600	8800	2610	2200	63.0
4D2-22	4.0	2900	8.0	0.16	130	59	- 50 to 200	12600	8800	2610	2200	63.0
6D2-22	6.0	3000	6.0	0.21	130	43	- 50 to 200	12600	8800	2610	2200	63.0

¹: In part reference values ²: Reference values

Reliability data

Item	Test conditions	Criteria
Resistance to soldering heat	10 s at 260 °C 5 s at 350 °C	ΔR ± 15%
Solderability	3 s at 245 °C Flux material: Rosin 25%, ethyl alcohol 75%	More than 95% soldered
Tensile strength (lead wire)	A load of 10 N is applied to the wire terminations in vertical direction for 10 s.	ΔR ± 15%
Voltage proof	1000 V AC for one minute	Less than 1 mA
Insulation resistance	500 V DC	Over 100 MΩ
Dry heat	1000 hours at max. operating temperature for each product number	ΔR ± 20%
Damp heat	1000 hours at 40 °C and 90% humidity	
Temperature cycle (thermal shock)	10 cycles as below: 1. - 40 °C for 30 minutes 2. Room temperature for 5 minutes 3. 160 °C for 30 minutes 4. Room temperature for 5 minutes	ΔR ± 15%
Electrical load	Max. current for 1000 h at 25 °C room temperature	ΔR ± 20%

Caution

- When force is applied to the lead wire the leg connections may break or chipping may occur.
- May get hot during use. When designing the environment around the power thermistor be especially careful with lead wire connections, materials used in the direct vicinity and the layout of other electrical components.
- Do not use two or more power thermistors in a row.



■ Non-contact (IR) temperature sensor

THERMOPILE

Thermopiles are IR temperature sensors that fully utilize SEMITEC original silicon-micromachining technology.

■ Product number

10TP583T

■ Applications

Ear thermometers, IR thermometers, microwave ovens and other non-contact temperature sensing applications

■ Specifications

Parameter	Value	Conditions
Sensitive area	1.05 x 1.05 mm	Size of absorbing film
Output voltage ¹	200 μ V \pm 30%	—
Output voltage ²	1.00 mV \pm 30%	—
Thermopile resistance	65 k Ω \pm 30%	Resistance value at 25 °C
Time constant	15 ms	Typical
Operating temperature range	- 20 to 100 °C	—
Storage temperature range	- 40 to 100 °C	—
Field of view	\pm 50°	Incident angle to achieve 50% responsivity
Filter range	Cut on 5 μ m	—
Thermistor resistance value	100 k Ω \pm 3%	Rated zero-power resistance value at 25 °C
Thermistor B value	3435 K \pm 0.7%	B value calculated from rated zero-power resistance at 25 °C and 85 °C

¹Test conditions

Blackbody furnace: 500 K
Sensor to blackbody distance: 100 mm
Sensor temperature: 298 K
Aperture size: ϕ 12.7 mm

²Test conditions

Blackbody furnace: 310 K
Sensor temperature: 298 K

■ Dimensions

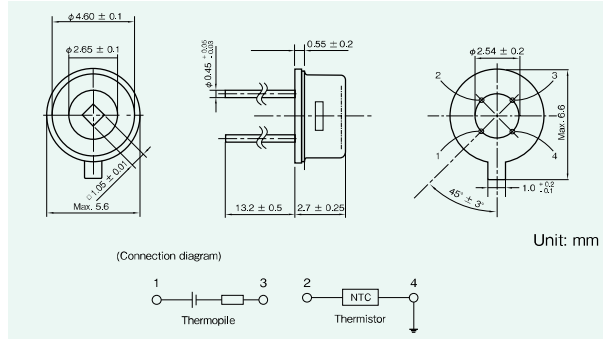

■ Optical characteristics

Field of view characteristics

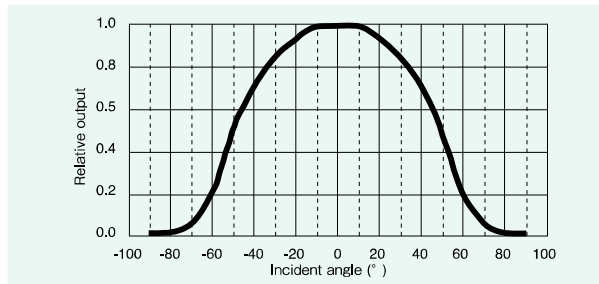

Filter characteristics

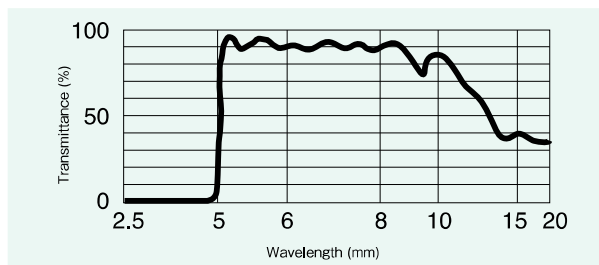

■ Reliability data

Item	Test conditions	Criteria
Dry heat	1000 hours at 100 °C	Thermopile: Δ V \pm 2% Thermistor: Δ R \pm 0.5% Thermistor: Δ B \pm 0.2%
Damp heat	1000 hours at 60 °C and 85% humidity	Thermopile: Δ V \pm 2% Thermistor: Δ R \pm 0.3% Thermistor: Δ B \pm 0.2%
Temperature cycle (thermal shock)	10 cycles as below: 1. - 20 °C for 30 minutes 2. Room temperature for 3 minutes 3. 100 °C for 30 minutes 4. Room temperature for 3 minutes	
Resistance to soldering heat	5 s at 350 °C	
Free fall	Three times natural fall to a concrete floor from 1 m height.	

■ Data table (approx.)

		Sensor temperature (°C)									
		- 20	- 10	0	10	25	40	60	80	100	
Temperature of measured object (°C)	- 20	0.000	- 0.510	- 1.081	- 1.718	- 2.809	- 4.078	- 6.078	- 8.473	- 11.31	
	- 10	0.510	0.000	- 0.571	- 1.208	- 2.300	- 3.568	- 5.568	- 7.963	- 10.80	
	0	1.081	0.571	0.000	-0.637	- 1.728	- 2.997	- 4.997	- 7.392	- 10.23	
	10	1.718	1.208	0.637	0.000	- 1.091	- 2.360	- 4.360	- 6.755	- 9.593	
	30	3.211	2.702	2.131	1.493	0.402	- 0.867	- 2.867	- 5.261	- 8.099	
	37	3.809	3.300	2.728	2.091	1.000	- 0.269	- 2.269	- 4.664	- 7.501	
	40	4.078	3.568	2.997	2.360	1.269	0.000	- 2.000	- 4.395	- 7.233	
	60	6.078	5.568	4.997	4.360	3.269	2.000	0.000	- 2.395	- 5.233	
	80	8.473	7.963	7.392	6.755	5.664	4.395	2.395	0.000	- 2.838	
	100	11.31	10.80	10.23	9.593	8.501	7.233	5.233	2.838	0.000	
	120	14.64	14.13	13.56	12.93	11.83	10.57	8.565	6.171	3.333	
	140	18.53	18.02	17.45	16.81	15.72	14.45	12.45	10.05	7.215	
	160	23.01	22.51	21.93	21.30	20.21	18.94	16.94	14.54	11.70	
180	28.17	27.66	27.09	26.45	25.36	24.09	22.09	19.70	16.86		
200	34.06	33.55	32.98	32.34	31.25	29.98	27.98	25.58	22.75		

Unit: mV